



# In-Line Inspection of Multi-Diameter Pipelines: Standardized Development and Testing for a Highly Efficient Tool Fleet

Dr. Hubert Lindner, Thomas Beuker and Martin Diekamp  
ROSEN Technology & Research Center (RTRC), Germany

## Introduction

In-line inspection (ILI) with various inspection methods such as Magnetic Flux Leakage (MFL) or Ultrasonic Technology (UT) has become standard in pipeline integrity assessment worldwide. Whereas approximately two thirds of the world's gas, oil and product pipelines can be inspected with off-the-shelf inspection tools, the remaining lines are currently classified as "unpiggable". However, many of these pipelines can be made inspectable through specific measures such as pipeline modifications and operational changes. Where asset modification is not feasible, the development of highly flexible and specialized inspection tools is the only viable solution to overcome issues related to in-line inspection.

One important factor in making pipelines difficult to inspect are significant variations in internal diameter, as, for example, in dual-diameter pipelines of 18/24 or 28/42 inches or even multi-diameter pipelines featuring multiple internal widths. Many of these multi-diameter pipelines were constructed before in-line inspection was invented, meaning that diameter was no consideration at the time. However, even new pipelines occasionally have varying diameters in order to accommodate, say, the requirements of risers in offshore transport lines or the limited space available on subsea templates. Whatever the reason for the inconsistencies in the internal diameter of assets, integrity assessment based on ILI technology is now mandatory, since it guarantees safe and efficient pipeline operation. Developing solutions to overcome the challenges posed by multi-diameter pipelines is therefore an important concern in the oil and gas industry.

## Development of Multi-Diameter Tools

In line with the development of ILI technology as a whole, the operating range of multi-diameter inspection tools has vastly increased in recent times. In the early days of pipeline inspection, tools sometimes even struggled with the relatively minor internal diameter changes found in single-size pipelines, to say nothing of narrow bends and other bulky installations. Over the years, ILI tools have improved both in terms of flexibility and measuring performance, giving rise to the first dual-diameter applications and an extension of 1.5D capability to include smaller pipeline diameters. As in-line inspection (particularly metal loss detection) became a universally accepted and legally required part of pipeline integrity, the demand for more difficult applications rose. The first multi-diameter tools for specific applications were soon developed for larger sizes and limited diameter ranges. Today, customized inspection solutions for multi-diameter pipeline systems are commonplace. This approach was taken, for example, in the Gassco-operated



Asgard Transportation System, an offshore project on the Norwegian Continental Shelf, and also in BP's Thunder Horse deepwater offshore project. Such assignments typically involve extreme development and testing efforts.

A customized inspection solution was developed by ROSEN to enable inspection of a 147 km long multi-diameter offshore pipeline in the North Sea beginning with a short 26" diameter section followed by a long 30" segment. The medium was gas, and the bends were not smaller than 3D. A specific challenge was posed by the need to reduce tool speed in relation to pipeline flow. As the section with the small internal diameter (ID) was only short (a few km) and at the start of the line, it was possible to implement a conventional solution with a special cup. To achieve full circumferential coverage and good magnetization in the 30" segment, two magnet units were used as shown in Figure 1. A first successful run was performed in March 2007.



Figure 1: ROSEN's 26"/30" multi-diameter MFL tool with speed control

Although this inspection tool was designed for a particular application and therefore features specific properties, it is still an often requested inspection tool for single-diameter pipelines, because of its speed control capability, its ability to pass through different diameters, its high magnetization levels, and its easily adaptable cup or disc setup. The only limitations of the ROSEN 26"/30" multi-diameter MFL tool are potential wear of its polyurethane (PUR) components and its inability to negotiate 1.5D bends.



Faced with a heavy-wall 14"/18" deepwater application in 2007, ROSEN took the development of its multi-diameter inspection tools one step further [1]. Once again, the tool was adapted to accommodate the specific features of the asset to be inspected:

- Pipeline length: 163.9 km
- Diameter: 14" for 11.9 km (wall thickness: 20.6 mm – 22.2 mm)
- Diameter: 18" for 151.9 km (wall thickness: 22.2 mm – 28.6 mm)
- Bends in the 14" section: 5D
- Bends in the 18" section: 5D
- Maximum water depth: 1900 m
- Maximum pressure: 290 bar
- Known minimum ID: 300 mm
- Internal wall: coated
- Medium: gas

Furthermore, the pipeline had several subsea appurtenances (notably check valves, connectors, ball valves, tees and reducers), two jumpers in the subsea connection segment, and an adjacent Y-piece. The transition from the 14" to the 18" section occurred in one leg of the Y-junction. This meant that one part of the cleaning or inspection tool had to expand its driving unit and pass the cavity of the Y-connection while its rear parts were still in the 14" pipeline.



Figure 2: The ROSEN 14"/18" test loop

Given that the tool was developed from scratch and that tool failure would have had serious consequences due to the location of the pipeline, a test loop mirroring the critical features of the line (check valves, Y-joint etc.) was designed and constructed (Figure 2). This test loop was used in all phases of tool development from the gauging tool to the complete Extended Geometry tool and the MFL tool (Figure 3).

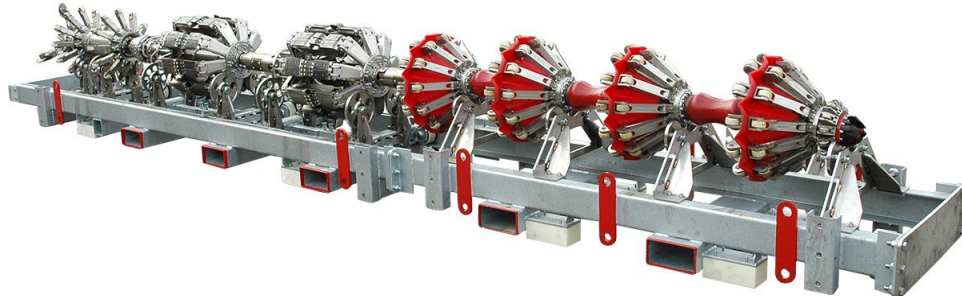

Figure 3: ROSEN 14"/18" multi-diameter MFL tool

Valuable data was gathered and experience gained during the test phase. The test runs notably led to a major improvement of the design which was necessary because of the interaction of bend passage and a connector cavity. In addition, the runs provided essential information about the run conditions likely to be encountered in the real pipeline.

#### **Standardization of Multi-Diameter Tool Development**

On the basis of experience gained in real-life applications in 2007 and estimates of likely future developments, ROSEN has since defined a set of simple criteria to classify multi-diameter tools in terms of their complexity and even their estimated feasibility for a given task [2]. This classification takes into account diameter variations, restrictions imposed by the narrowest bend, and the absolute size of the pipeline.

To render the development of the multi-diameter tools even more efficient, development researchers increasingly began to separate the two essential aspects of a tool: its pulling component, which ensures tool movement through the pipeline, and its measurement (or cleaning) technology component. In terms of the tool's pull unit, this standardized development method enables optimization of the general requirements through a number of basic design options, including:

- 1.5D capability even in the smallest required pipeline size, if it not collides with other requirements (e.g. overall range or reasonable body length)
- Ability to pass through all general installations (full bore tees, diameter transitions)
- Modular design, to ensure capacity to handle Y-junctions in particular
- Standardized sub components and technologies
- Additional options such as a speed control function

The ability to pass Y-connections is explicitly mentioned not only because this is a common installation feature of subsea pipeline systems, but more importantly because such connection types are typically used where a smaller line leads into a larger transport line, thereby resulting in a diameter change.



The advantage of this standardized approach involving separation of components is that it creates considerable flexibility for the development process: the diameter range of a pull unit can be designed without the need to develop a measuring or cleaning segment at the same time and therefore without having to consider the particular requirements arising from such a unit.

An example of the separate and standardized development approach is the pull unit for the 14"/20" MFL and Extended Geometry tool (see Figure 4) with the following basic design features:

- Multiple single segments
- Special semi-rigid connections to stabilize the segments
- Centralized wheel support system
- Basic mechanical solutions for certain size ranges
- Multi-diameter cups (connected to the support system)

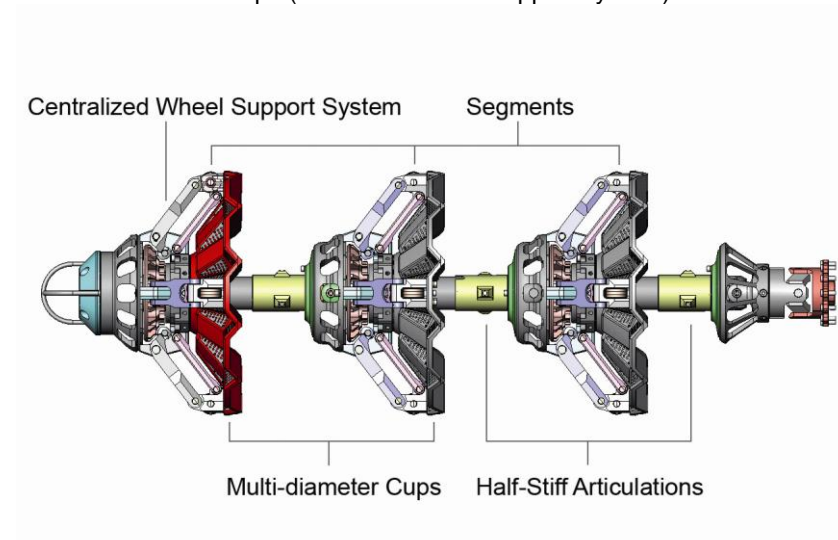

Figure 4: Drawing of the 14"/20" pull unit

The combination of short segments and special joints allows safe 1.5D passage even in 14" diameter pipelines. Due to the unit's modular structure, as many segments as required can be used, for example to ensure sealing of the cavity while the tool passes through a Y-junction. This design also enables the tool to negotiate other common installations such as check valves and full bore tees.

Similar to the pull unit, the separate development of the measuring and electronic units has also led to innovative solutions. In this tool segment too, all measuring units are centralized by different mechanisms to ensure optimal measurement quality for all measurement instruments. Most measurement units run on wheels to prevent wear by reducing friction. Figure 5 shows the complete 14"/20" MFL tool.

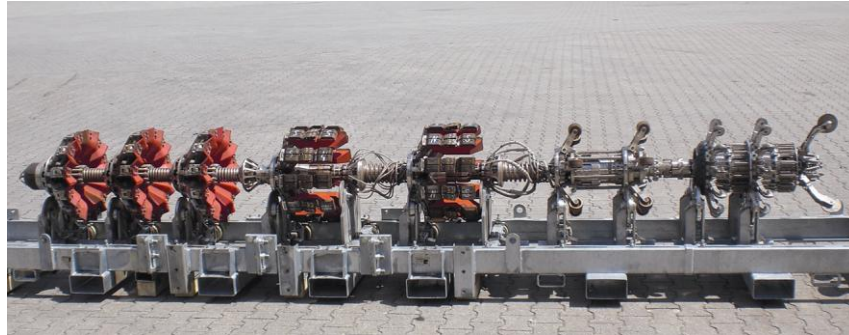

Figure 5: Complete 14"/20" MFL Tool

The 14"/20" MFL tool as a whole can be considered a standardized multi-diameter solution for medium pipeline sizes. It consists of a modular pull unit and two magnet segments (for circumferential coverage) and two wheel-supported electronic parts. It has full 1.5D bend capability in 14" lines and can cope with all common types of installations.

Since relatively more space becomes available with increasing pipeline diameter and higher flow rates are typically present in larger lines, a different standard was developed for larger pipe sizes. This standard notably takes into account the need for speed control arising from fast-flowing media. The remaining requirements are similar to those of medium-sized pipelines: 1.5D bend capability, separate pull unit, basic mechanical solutions and safe negotiation of standard installations.

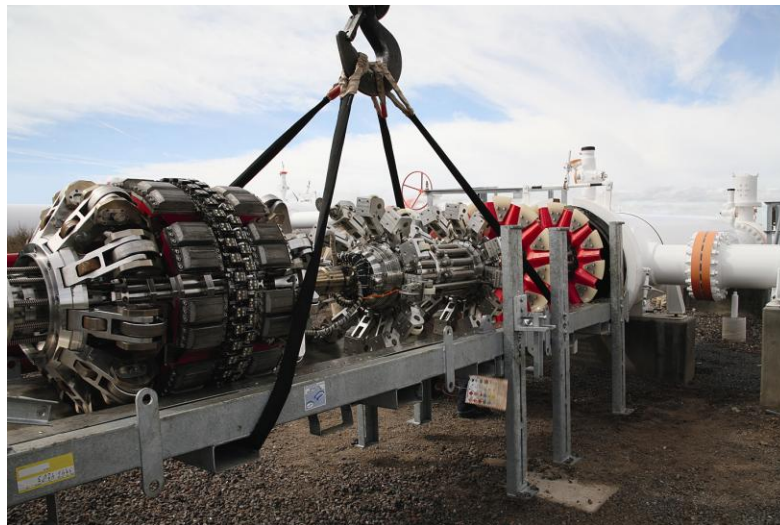

Figure 6: The 30"/36" MFL tool with speed control before inspection run



Figure 6 shows the realized basic design concept of larger multi-diameter tools. The tool's identical pull unit segments can carry either a speed control valve or the battery / electronics compartment. Where required, these segments can additionally be equipped with multi-diameter cups on each support plane. A particular improvement has been achieved with the design of the magnet unit: using a special support technique, ROSEN has managed to construct a multi-diameter magnet unit which not only consists of one single segment but features a unique flexible sensor ring allowing circumferential sensor coverage for all sizes.

An overview of the current status of the ROSEN multi-diameter tool fleet is given in Table 1. It includes all currently available and projected tools. It is worth pointing out that even the very small 6"/8" tool still requires the same solutions as larger multi-diameter tools.

	1.5D bend capability	MFL unit	Extended geometry unit	Speed control
6"/8"	in 8"	Yes	Yes	No
12"/18"	≥ 12"	Yes	Yes	No
14"/20"	≥ 14"	Yes	Yes	No
18"/24"	≥ 18"	Yes	Yes	No
24"/32"	≥ 24"	Yes	Yes	Yes
30"/36"	≥ 30"	Yes	Yes	Yes
32"/42"	≥ 36"	Yes	32"/40" (36"/42")	Yes

Table 1: ROSEN's multi-diameter tool fleet

### Multi-Diameter Test Procedure

Thorough testing of newly developed multi-diameter tools is important for a number of reasons. Firstly, each new tool tends to exceed the range of existing experience due to extended specifications. Secondly, tool designs change significantly from one development to the next. Thirdly, it must be ensured that despite their extended specifications and altered design, new tools are still capable of negotiating different pipeline segments and installations. Finally, run behavior and operational conditions must be tried and tested before actual field applications to ensure tool safety and reliability. For all these reasons, ROSEN has developed a special multi-diameter tool test program which typically includes the following steps:



1. Pull test for all relevant pipeline sizes  
While the tool is pulled through pipelines of the relevant size, pulling forces are measured and deformation behavior is monitored. Pulling is also used for tool functional and calibration testing.
2. Flip-over / sealing test in the largest diameter  
Pressure and flow are monitored to evaluate sealing capability and detect the flip-over pressure.
3. Pump test in full-scale test loop  
The test loop includes at least the extreme elements of the tool specifications (1.5D bend in the smallest relevant diameter size, heavy wall segment in the smallest pipeline size for passage, largest relevant pipeline diameter, full bore tee in the largest pipe size and at least one transition between the extreme diameters). Monitoring the flow and pressure during the pump test supports prediction of run behavior. If required, special installations can be simulated as well. Pump tests are typically carried out with water as the propellant.

Due to the current developments, ROSEN currently is operating as many as ten pump test loops, five of these are multi-diameter. An example of a 32"/42" test loop is given in Figure 7. Apart from diameter transitions of 32" to 36", 35" to 40" and 40" to 42", this particular test run features four bends (32", 36", 40" and 42").



Figure 7: Pump test loop for 32"/42" multi-diameter tools



### **Field Experience with Multi-Diameter Tools**

The importance of the multi-diameter test procedure has been confirmed on numerous occasions by the excellent first run success rates achieved. All of the configurations shown in Table 1 have been successfully operated in several pipeline inspection surveys. All of them covered the entire diameter range. And for a special application the 12"/18" pull unit has been used as a tractor for a 12" MFL tool in a 12"/18" pipeline.

While the first runs of all multi-diameter tools developed were successful without exception thanks to the intensive test phase and careful project preparation, the standardized tools offering the biggest operating range in particular showed very good performance and were in excellent condition after the run (see Figure 6 above). Over and above liquid pipelines, the tools have also proved their efficiency and reliability in four gas lines with varying diameter combinations.

### **Conclusions**

Although multi-diameter pipelines pose major cleaning and inspection challenges, increasingly stringent legal requirements for asset integrity call for ever more complex inspection solutions. To meet these industry demands with the greatest degree of flexibility and cost-efficiency, ROSEN has conceived a standardized process for the development of highly maneuverable and reliable tools to ensure accurate in-line inspection and thorough asset cleaning. This development system is complemented by a special multi-diameter tool test procedure the effectiveness of which has been repeatedly shown in field applications. Given the success of both the development system and the testing procedure established, ROSEN intends to use these as the basis for future multi-diameter tool designs. The group thus looks set to continue to make an important contribution to overcoming one of the major challenges facing the oil and gas industry.

### **References**

- [1] Lindner, H.: Meeting the Challenge of Deep Water In-Line Inspection. In: International Oil & Gas Engineer 02 – 2009.
- [2] Beuker, T.; Lindner, H.: Classifying Pipeline Complexity. In: World Pipelines – March 2007.